

TYPE "B" SINGLE STAGE CENTRIFUGAL PUMP Electric Motor Drive

Section	CC
Page	130.3
Date	January 1, 2004
Supersedes 6/1/95	

CAST IRON IMPELLER

B2-1/2ZPLS

Threaded Case (NPT)

Mechanical Shaft Seal Construction

TABLE I

B/M No.	HP	PH	RPM	"U" Dim.	Imp. Dia.	Imp. No.
B54092	20	3	3600	1-1/4"	7.69"	M07678
B54093	25	3	3600	1-1/4"	8.44"	M07688
B54094	30	3	3600	1-1/4"	8.88"	M07689

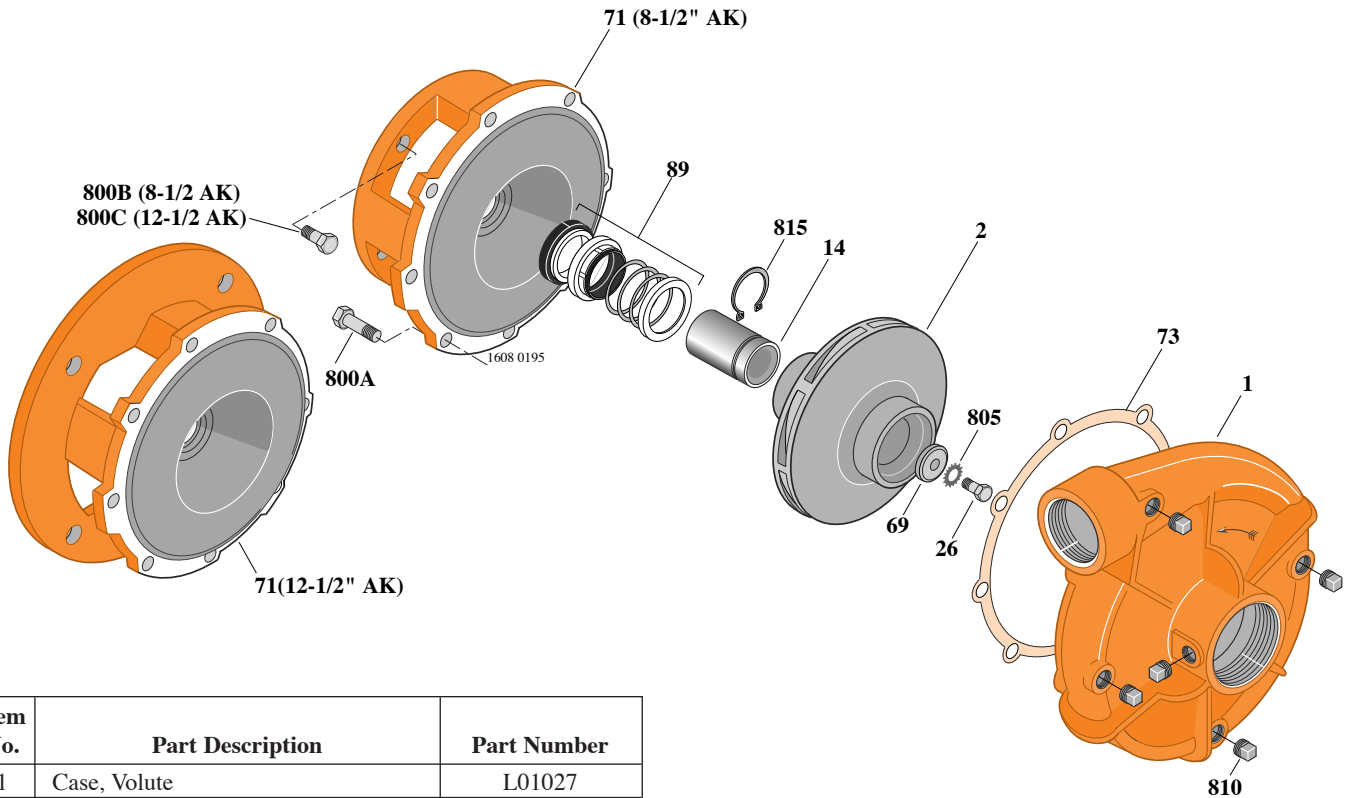

Item No.	Part Description	Part Number
1	Case, Volute	L01027
2	Impeller	See Table I
14	Sleeve, Shaft	S18869
26	Screw, Impeller 1/2 - 13 x 1"	S23619
32	Key, 1/4 x 2-1/4" (See Note)	S23677
69	Washer, Impeller	S06319
71	Bracket	See Table II
73	Gasket, Volute	S05126
89	Seal, Mechanical Shaft	S32015
800A	Capscrew, 3/8 - 16 x 7/8" (8 Req.)	S26825
800B	Capscrew, 1/2 - 13 x 1" (4 Req.)	S26912
805	Washer, Lock	S23038
810	Plug, Pipe 1/4 NPT (5 Req.)	S23715
815	Ring, Retaining	S16767

TABLE II

HP	PH	Bracket No.	"AK" Fit	"U" Dim.	Motor Frame
20	3	L04615	8-1/2"	1-1/4"	254JM
25	3	L04615	8-1/2"	1-1/4"	256JM
30	3	L04627	12-1/2"	1-1/4"	284JM

NOTE: For an explanation of the tabulated material found on this page and for impeller key location, refer to *Supplement A* located at the beginning of this section.